



## PRODUCT CONFIGURATION

### PRODUCT IDENTIFIER **1**

**OM** = Oval Gear Meter

### METER SIZE **2**

**015** = 1/2" (15 mm), 0.26-10.6 GPM (1-40 L/min)

**025** = 1" (25 mm), 2.6-40 GPM (10-150 L/min)

**040** = 1-1/2" (40 mm), 4-66 GPM (15-250 L/min)

**050** = 2" (50 mm), 8-118 GPM (30-450 L/min) with SS Rotors

**050** = 2" (50 mm), 8-130 GPM (30-500 L/min) with PPS Rotors

### BODY MATERIAL **3**

**A** = Aluminum

**M** = Intermediate pressure aluminum meter (2000 psi [138 bar] max.) (OM025 only)

**S** = 316L Stainless Steel

**N** = Intermediate Pressure 316L SS (OM015-OM025N = 1450 psi [100 bar]) (OM040N-OM050N = 725 psi / 50 bar)

### ROTOR MATERIAL / BEARING TYPE **4**

**00** = PPS (not available for 300° F [150° C] meters) / No bearing

**10** = Keishi cut PPS (for high viscosity liquids) (not available for 300° F [150° C] meters) / No bearing

**51** = Stainless Steel / Carbon Ceramic

**71** = Keishi cut Stainless Steel (for high viscosity liquids) / Carbon Ceramic

### O-RING MATERIAL **5**

**1** = FKM (Viton™) (standard for Alum.) 5° F minimum (-15° C)

**3** = PTFE encapsulated FKM (Viton™)

**4** = Buna-N (Nitrile), -40° F minimum (-40° C)

### MAXIMUM TEMPERATURE LIMIT **6**

**-2** = 250° F (120° C) max.

**-3** = 300° F (150° C) max. (Hall Effect) (Includes Stainless Steel terminal cover)

**-5** = 250° F (120° C) max. (includes integral cooling fin)

**-8** = 176° F (80° C) max. (meters with integral instruments)

### PROCESS CONNECTIONS **7**

**0** = No fittings (Not available on 015 size)

**1** = BSPP (G) female threaded (ISO 228)

**2** = NPT female threaded

**3** = Sanitary Fittings (are 1/2" (13 mm) larger than meter size)

**4** = ANSI-150 RF Flanged

**5** = ANSI-300 RF Flanged

**6** = PN16 DIN Flanged

### CABLE ENTRIES **8**

**1** = M20 x 1.5 mm (M16 x 1.5 mm for R4 option)

**2** = 1/2 in. NPT

**6** = 3 x 16 mm drilled holes (for F instruments only)

## OM SERIES MEDIUM CAPACITY (OVAL GEAR METERS)

The FLOMEC® OM Medium Capacity Meters are great for medium flow ranges and have the ability to handle a wide range of fluid viscosities.

## FEATURES / BENEFITS

- High accuracy and repeatability, direct volumetric reading
- Measures high and low viscosity liquids
- Quadrature pulse output option and bi-directional flow
- Optional Exd I/IB approval (ATEX, IECEx)
- No requirement for flow conditioning (straight pipe runs)
- Only two moving parts

## INTEGRAL OPTIONS **9**

\_\_\_ = Combination Reed Switch and Hall Effect Sensor

**SS** = Stainless Steel terminal cover

**RS** = Reed Switch only - to suit Intrinsically safe installations

**E1** = Explosion proof Exd IIB T3...T6 (Aluminum & Stainless meters) [IECEx & ATEX approved]

**E2** = Explosion proof Exd I/IB T3...T6 (stainless meters only) [IECEx & ATEX mines approved]

**QP** = Quadrature pulse (2 NPN phased outputs)

**QPN** = Quadrature pulse (2 NPN phased outputs) with Australian NZNMI approval for trade sale

**Q1** = Explosion proof Exd (with quadrature pulse) [IECEx & ATEX approved]

**Q1N** = Explosion proof Exd (IECEx & ATEX) with Quadrature pulse with Australian NMI & NZ approval for trade sale (Not available on 015 size)

**R3** = Intrinsically safe RT12 with all outputs (GRN housing) [IECEx & ATEX approved]\*#

**R3G** = RT12 Intrinsically Safe rate totalizer with all outputs (GRN Housing) [IECEx & ATEX approved] (with gallons calibration)\*#

**R4** = RT40 rate totalizer with backlit large digit LCD [scalable pulse output, backlight]\*#

**R4G** = RT40 rate totalizer with backlit large digit LCD (Alloy housings with facia) (with gallons calibration)\*#

**R5** = RT14 backlit rate totalizer with all outputs (GRN Housing)\*#

**R5G** = RT14 backlit rate totalizer with all outputs (GRN Housing) (with gallons calibration)\*#

**E18** = E018 backlit rate/tot, pulse, 4-20mA, 10 point linearization, HART, aluminium body [IECEx & ATEX approved] (Not available with 015 size)#

**E19** = E018 backlit rate/tot, pulse, 4-20mA, 10 point linearization, HART, stainless steel body [IECEx & ATEX approved] (Not available with 015 size)#

**F18** = F018 backlit rate/tot, pulse, 4-20mA, 10 point linearization, HART#

**F19** = F018 backlit rate/tot, pulse, 4-20mA, 10 point linearization, HART, Intrinsically safe [IECEx & ATEX approved]#

**F31** = Intrinsically safe F130 2 stage batch controller [IECEx & ATEX approved]#

--->>>> **1 2 3 4 5 6 7 8 9**  
OM 025 A 51 2 -5 2 1 R4

\*Temp code 5 required for integral instruments between 176°F (80°C) & 250°F (120°C)  
#Temp code 8 required for integral instruments below 176°F (80°C) by 20%

# SPECIFICATIONS

	OM015	OM025	OM040	OM050
Nominal Size:	1/2" (13 mm)	1" (25 mm)	1 1/2" (38 mm)	2" (51 mm)
*Flow Range:	0.26-10.6 GPM (1-40 L/min)	2.6-40 GPM (10-150 L/min)	4-66 GPM (15-250 L/min)	8-118 GPM (30-450 L/min) (SS) 8-130 GPM (30-500 L/min) (PPS)
Accuracy @3cp:	± 0.5% of reading (accuracy is ± 0.2% of reading with optional RT14 with non-linearity correction)			
Repeatability:	Typically ± 0.03% of reading			
Temperature Range:	-40° F to +300° F (-40° C to +150° C) refer to factory for lower temperature			
<b>Pressure Rating (Threaded Meter):</b>				
Aluminum	990 psi (68 bar)	990 psi (68 bar)	435 psi (30 bar)	285 psi (20 bar)
Intermediate Pressure Aluminum		2000 psi (138 bar)		
316 Stainless Steel	990 psi (68 bar)	990 psi (68 bar)	435 psi (30 bar)	550 psi (38 bar)
Intermediate Pressure SS	1450 psi (100 bar)	1450 psi (100 bar)	725 psi (50 bar)	725 psi (50 bar)

	OM015	OM025	OM040	OM050
<b>Pressure Rating (Mechanical Meter):</b>				
Aluminum	580 psi (40 bar)	580 psi (40 bar)	435 psi (30 bar)	285 psi (20 bar)
316 Stainless Steel	580 psi (40 bar)	580 psi (40 bar)	435 psi (30 bar)	285 psi (20 bar)
Recommended Filtration	100 mesh (150 µm)			
<b>Electrical:</b>				
Output Pulse Resolution:	Pulses / gallon (Pulses / L) - Nominal			
Reed Switch	318 (84)	120 (27)	53 (14)	25 (6.5)
Hall Effect	636 (168)	405 (107)	212 (56)	99 (26)
QP - Quadrature Hall Option	636 (168)	204 (54)	106 (28)	49 (13)
Reed Switch Output	30V (dc) x 200mA max. [maximum thermal shock 18° F (10° C) / minute]			
Hall Effect Output (NPN)	3 wire open collector, 5-24V (dc) max., 20mA max.			
Optional Outputs	4-20mA, scaled pulse, quadrature pulse, flow alarms or two stage batch control			

\*Maximum flow is to be reduced as viscosity increases, see flow de-rating guide. Max recommended pressure drop is 14.5 psi (1 bar).

# DIMENSIONS

All dimensions are ± .079 (±2 mm)

Modular Fitting	A					
	OM015	OM025A	OM025S/N	OM040	OM050	OM050E
A.N.S.I. 150 DIN16	7.4" (189 mm)	7.8" (198 mm)	9.3" (237 mm)	9.9" (252 mm)	10.9" (277 mm)	10.9" (277 mm)
B.S.P N.P.T.	4.3" (110 mm)	5.4" (137 mm)	6.9" (176 mm)	7.4" (188 mm)	8.3" (212 mm)	8.3" (212 mm)

Configuration	B							
	OM015A	OM015S/N	OM025A	OM025S/N	OM040A	OM040S/N	OM050	OM050E
RT12 / RT14 GRN Housing	6.0" (154 mm)	5.8" (148 mm)	6.6" (168 mm)	6.5" (165 mm)	7.9" (203 mm)	7.6" (194 mm)	8.6" (218 mm)	10.5" (268 mm)
RT40 Alloy Housing	6.2" (157 mm)	5.9" (151 mm)	6.7" (171 mm)	6.6" (168 mm)	8.1" (206 mm)	7.8" (197 mm)	8.7" (221 mm)	10.7" (271 mm)
Cover	4.2" (106 mm)	3.9" (100 mm)	4.7" (123 mm)	4.6" (117 mm)	6.1" (155 mm)	5.7" (146 mm)	6.7" (170 mm)	8.6" (220 mm)

# APPLICATIONS

- Oils
- Fuel
- Diesel
- Truck Metering
- Bunker C Fuel Oil
- Chemical Additive Injection
- Batching
- Molasses
- Clean Fluids
- Oil-Based Paints
- Industrial Fluids
- Chemical Feed Lines

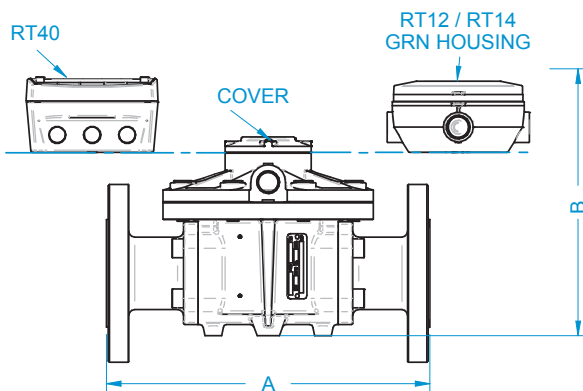

OM040: Ø6.3" (160 mm)  
 OM050: Ø7.1" (180 mm)  
 OM015: Ø4.3" (110 mm)  
 OM025: Ø4.7" (120 mm)

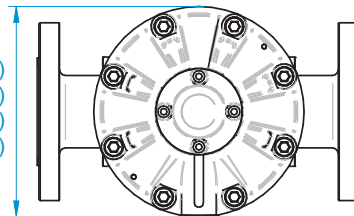

# APPROVALS



**Service & Warranty:** For technical assistance, warranty replacement or repair contact your FLOMEC® or GPI® distributor:

In North or South America: 888-996-3837 / FLOMEC.net

Outside North or South America: +61 2 9540 4433 / FLOMEC.net

Wichita · Sydney





## E SERIES EXPLOSION PROOF TOTALIZER & FLOW RATE INDICATOR

### BENEFITS

- Save time with the easy-to-operate through glass keypad: no need to remove the front cover nor to arrange a work permit
- Easy installation with the spacious chamber and plug and play connectors
- Long life duration in extremely salty atmospheres (offshore) with heavy duty stainless steel Exd enclosure
- Key information at a glance as the display shows flow rate, total, measuring units and a flow rate indicating speedometer

### FEATURES

- Selectable on-screen engineering units; volumetric or mass
- 7 digit flow rate / total and 11 digit accumulated total
- 16 point linearization of the flow curve - with interpolation
- Power options: Loop powered, battery and 8 - 30V (dc)
- Isolated, loop powered 4 - 20mA output according to linearized flow rate
- Scaled pulse output according to linearized accumulated total
- Ability to process all types of volumetric or mass flowmeter signals: Reed-switch, NAMUR, NPN/PNP pulse, Sine wave (coil), Active pulse signals. (0)4 - 20mA and 0 - 10V (dc) analog inputs are pending.
- HART communication

## APPLICATIONS

The E018 by FLOMEC® offers you an enclosure designed to be used in rough and tough applications, beyond being just explosion proof. Its sturdy design and ease of use are unequalled by any other explosion proof indicator in the market. The E018 is always your first and safest choice in explosion proof applications.

## PRODUCT CONFIGURATION

### STANDARD CONFIGURATION 1

**E018** = Flow Rate Monitor / Totalizer - Alarms - HART

### FLOWMETER INPUT SIGNAL 2

**P** = Pulse input: Coil, NPN, PNP, Namur, Reed-switch

### ANALOG OUTPUT SIGNAL 3

**AH** = Galvanically isolated, Loop powered 4-20mA output

### COMMUNICATION 4

**CR** = HART communication

### ENCLOSURE TYPES 5

**HAD** = Diecast Aluminum Enclosure, Entry threads: 2" x 1/2" NPT / 1" x 3/4" NPT

**HSD** = Stainless Steel Enclosure, Entry threads: 2" x 1/2" NPT / 1" X 3/4" NPT

### ADDITIONAL INPUTS 6

**IB** = Remote input to reset total or to lock the "Clear Total" button

### OUTPUTS 7

**OT** = Passive transistor output - standard configuration

### POWER REQUIREMENTS 8

**PD-PB** = 9 - 27 V (dc) + sensor supply, Lithium battery power

### HAZARDOUS AREA 9

**XD** = Explosion proof enclosure according ATEX & IECEx (CSA and FM Pending)

### OTHER OPTIONS 10

**ZB** = Backlight is included as standard

1 2 3 4 5 6 7 8 9 10  
>>>> E112 P AH CX HAA IB OT PX-PB XD ZB

## SPECIFICATIONS

Display:	
Type	High intensity transreflective numeric and alpha-numeric LCD, UV resistant, with bright backlight. Intensity can be adjusted via keypad.
Digits	Seven 0.47" (12 mm) and eleven 0.28" (7 mm) digits. Various symbols and measuring units.
Refresh rate	User definable: 8 times/s to 30 s.
Speedometer	To indicate the actual flow rate the bargraph runs from 0 to 100% in 20 blocks, each block is 5%.

Operating Temperature (Operational):	
-40°F to +158°F (-40°C to +70°C)	

Power Requirements:	
9 - 27V (dc). Power consumption maximum 4.2 Watt. Long life Lithium battery - lifetime depends upon settings and configuration - up to approximately 2 years	

Hazardous Area - Explosion Proof:	
ATEX Certification:	Ex II 2 G Ex IIC T6 Gb Ex II 2 D Ex IIIC T85°C Db
IECEX Certification	Ex d IIC T6 Gb Ex tb IIIC T85°C Db
FM / CSA c-us Certification	Explosion-proof for use in Class I, Division 1, Groups A, B, C, D DIP (Dust-Ignition-proof): Class II, Division 1, Groups E, F and G. Class III, hazardous (classified) locations
Ambient to:	-40°F to +158°F (-40°C to +70°C)

Hazardous Area - Directives:	
EMC:	Compliant ref. EN61326-1 and FCC 47 CFR part 15
Low voltage:	Compliant ref. EN61010-1

Signal Input (Flowmeter):	
	Coil / sine wave (COIL-HI: 20mVpp or COIL-LO: 80mVpp - sensitivity selectable), NPN / PNP, open collector, reed switch, Namur, active pulse signals 8 - 12 and 24V (dc)
Frequency:	Minimum 0Hz - maximum 7 kHz for total and flow rate. Maximum frequency depends on signal type and internal low-pass filter. E.g. reed switch with low-pass filter. Maximum frequency 120Hz.
K-Factor	0.000010 - 9,999,999 with variable decimal position
Low-pass filter	Available for all pulse signals

External Reset Total:	
Function:	<ul style="list-style-type: none"> <li>Terminal input to reset total remotely</li> <li>If this terminal input is closed, the "clear total" function is disabled</li> </ul>
Type:	Internally pulled-up switch contact - NPN
Duration:	Minimum pulse duration 100ms

Signal Output (Digital):	
Function:	Pulse output. Transmitting accumulated total
Frequency:	Maximum 500Hz. Pulse length user definable between 1 ms up to 10 seconds
Type OT:	One passive transistor output (NPN) - not isolated. 300mA - 50V @ 77°F (25°C)

Signal Output (Analog):	
Function:	Transmitting linearized flow rate
Accuracy:	12 bit. Error < 0.1%. Analog output signal can be scaled to any desired range.
Type AH:	Galvanically isolated, loop powered 4-20mA output

Accumulated Total - 11 digits:	
Units / Decimals:	According to selection for total
Note:	Can not be reset to zero

Flow rate - 7 digits, 0 - 1 - 2 or 3 decimals:	
Units:	mL, L, m³, Gallons, kg, Ton, lb, bl, cf, RND, ft³, scf, Nm³, NI, iganal - no units
Time units:	/s - /min - /hr - /day

## ACCESSORIES

Part No.	Description
FW-ABB04	1 X 3/4 inch NPT plug
FW-ABB05	1 X 1 inch NPT plug
1522068	E-Series Wall Mount Kit
1522051	E-Series Pipe Mount Kit

## APPROVALS



## DIMENSIONS

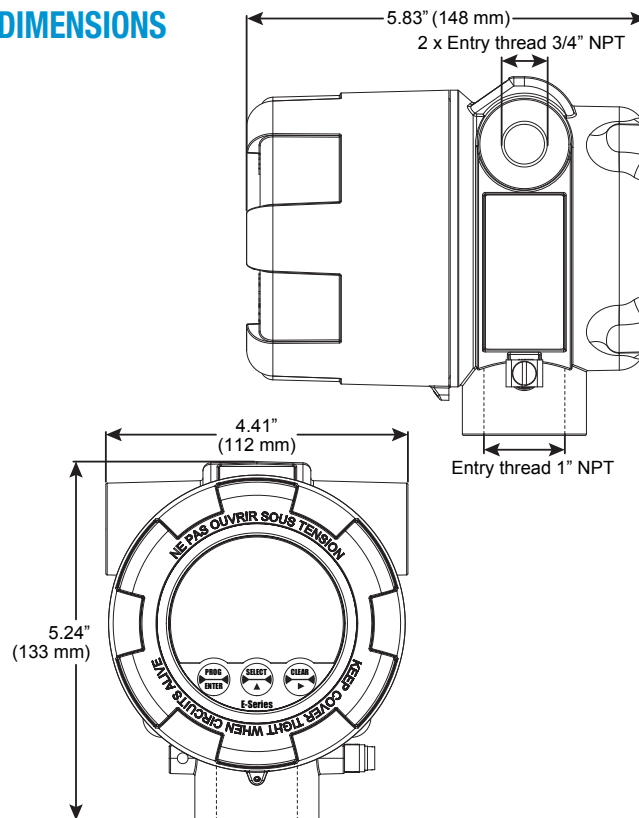

**Service & Warranty:** For technical assistance, warranty replacement or repair contact your **FLOMEC®** or **GPI®** distributor: In North or South America: **888-996-3837 / FLOMEC.net**  
Outside North or South America: **+61 2 9540 4433 / FLOMEC.net**





## EB11 'EasyBatch' CONTROLLER

The FLOMEC EB11 “EasyBatch” is a dual stage batch controller designed to create an efficient and accurate dispensing experience. Mountable either directly onto a FLOMEC® flow meter or remotely, and compatible with multiple types of industry signals, the EB11 allows the user to control the volume of fluid dispensed into their process, while the large 7-digit display with back light enables easy reading of the batch status in either light or dark conditions. Housed in an IP66/67-NEMA4X rated Glass Reinforced Nylon enclosure for increased impact and corrosion resistance, particularly in washdown environments. The EB11 contains 2 digital NPN outputs with a current rating of up to 300mA for direct control of solenoid valves, or to connect to relays to allow for the control of large valves and pumps.

## FEATURES

- Easy to use 2 button controller
- Weather resistant and durable IP66/67 - NEMA4X enclosure
- Easy to read backlit 7-digit display
- Retained settings after power loss

## PRODUCT CONFIGURATION

### PRODUCT IDENTIFIER **1**

**EB11** = EasyBatch dc powered dual stage batch controller

### ELECTRICAL ACCESS **2**

**1** = M20 x 1.5 mm female threaded conduit entry ports (sealed ports remain IP66/67 when not used)

**2** = 1/2 in. NPT female threaded conduit entry ports

### FLOW INPUT TYPE **3**

**D** = Digital (pulse or frequency)

### POWER SUPPLY **4**

**0** = Self-powered (battery) or regulated 8-24v (dc)

### HOUSING TYPE **5**

**FM** = Universal mount (field or panel) - GRN housing

**MM** = Integral meter mount - GRN housing\*

\*MM when retrofitting an instrument to OM series pulse meters

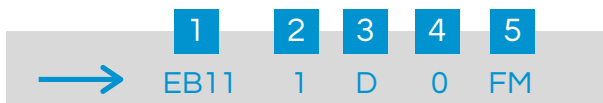

## ACCESSORIES (for above series)

1522001	Stainless steel wall mount kit
1522002	Stainless steel 2 in. pipe mount kit
1502015	Cooling fin kit for flow meters with integral instruments ( for operating between 60°C [140°F] and 100°C [212°F])
1322039	ADM M20-M16 metric adapter
1319006	M16 cable gland
1511002	6-core screened instrument cable

## SPECIFICATIONS

<b>Display</b>	12 mm 7-digit batch total and 7 mm 7-digit batch preset
<b>Engineering Units</b>	Liters, gallons, m <sup>3</sup> , lbs, kgs, or no engineering units
<b>Input Types &amp; Max Frequency</b>	Namur (4kHz), Reed-switch (120 Hz), NPN (6kHz), PNP (6kHz) and coil.
<b>Control Outputs</b>	GRN housing: 2x 300mA NPN Open Collectors, 24v (dc)
<b>Operating Temperature</b>	Field Mount: -10°C - +60°C (14°F - +140°F)
<b>Enclosures</b>	Field Mount: GRN Housing, IP66 (NEMA4X)
<b>Power Requirements</b>	Field Mount: 10-30v (dc)
<b>Mounting Options</b>	Meter or stem mount, wall, surface, pipe or panel mount*

*\*Panel mount seal kit required to maintain IP66/67 rating when separating from rear housing for mounting when using GRN housing.*

## DIMENSIONS / FIELD MOUNT

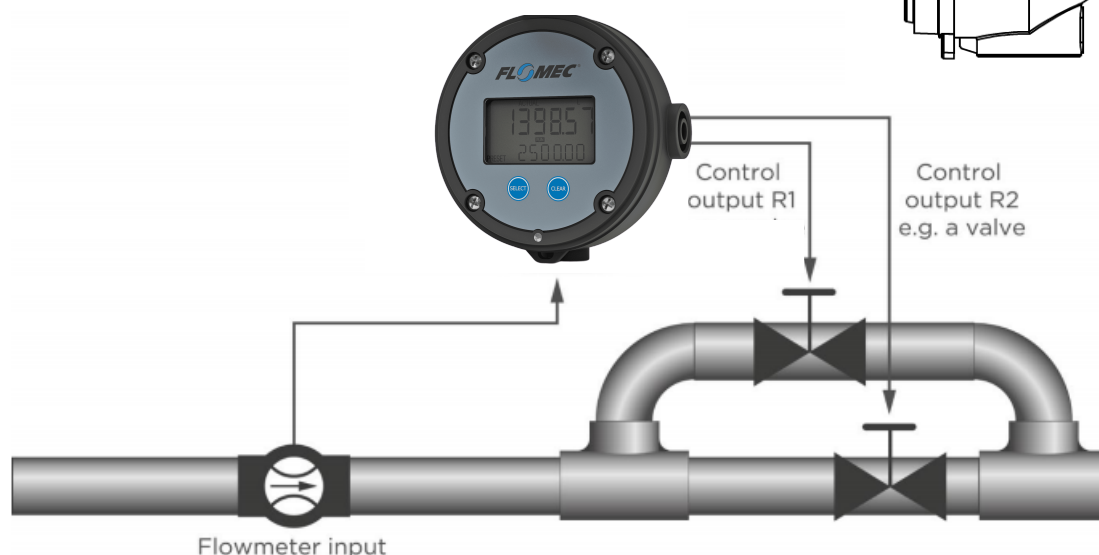
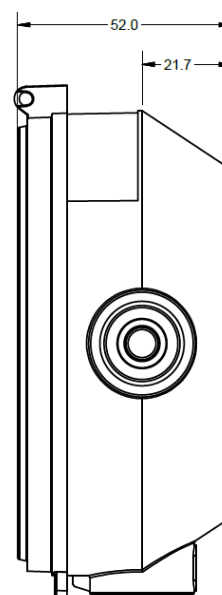
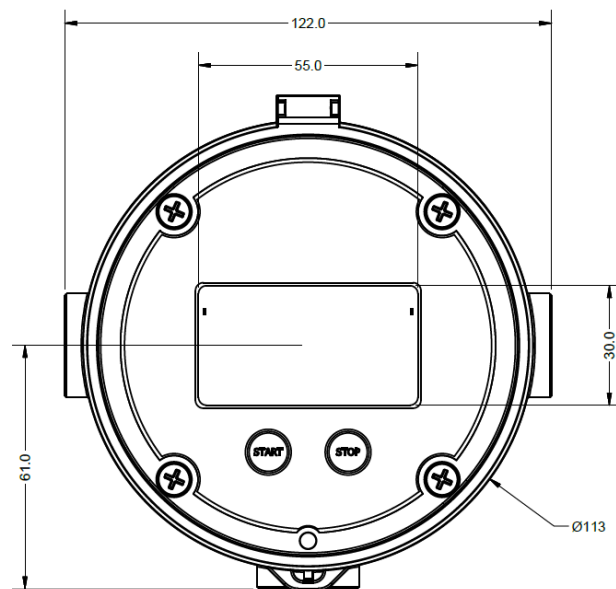



## F SERIES (REMOTE PANEL MOUNT ELECTRONICS)

Top of the line specialty electronics by **FLOMEC® F Series Electronics** are designed with several different input and output options. Rugged and dependable, the F Series offers:

- Field-mountable
- Easy programming with a sensible menu-driven structure
- Large 0.67" (17 mm), 7 digit display
- Accepts several different input signals

## FEATURES / BENEFITS

- Batching
- Net Use
- 4-20 mA Output
- HART Protocol
- High Low Alarms
- Linearization
- Two Stage Valve Control
- Temperature Compensation

## APPLICATIONS

- The F-Series is your first and safest choice for fieldmount indicators. Especially in harsh weather conditions like rain, snow, salty atmospheres and temperatures between -40°F up to +176°F (-40°C up to 80°C) for safe and hazardous area applications.
- Applications where net flow calculation at base conditions is desired without the influence of thermal product expansion.
- Liquid flow measurement with mechanical flowmeters where a precise calculation over the full measurement range is required. Also continuous flow rate monitoring is required.
- For batching small up to very large quantities. Single or repeating batches.
- Fuel consumption calculation for diesel engines on board of ships or trains. Sum function: where flows are split-up in two pipe-lines and total flow has to be calculated.

## APPROVALS

IECEX



## PRODUCT CONFIGURATION

### STANDARD CONFIGURATION 1

- F018** = Flow Rate Monitor / Totalizer - Linearization & Alarms
- F115** = Flow Rate Monitor / Totalizer - Bi-Directional - Quadrature
- F127** = Differential / Sum Flow Computer - Net Use - Temp Correction
- F130** = Batch Controller - Two Stage

### FLOWMETER INPUT SIGNAL 2

**P** = Pulse input: Coil, NPN, PNP, Namur, Reed-switch

### ANALOG OUTPUT SIGNAL 3

- AP** = Passive 4-20mA output, loop powered unit (F115 & F127)
- AH** = Galvanically isolated, loop powered 4-20 mA output (F018)
- AX** = No analog output (F130)

### COMMUNICATION 4

- CR** = HART Communication (F018)
- CX** = NO communications (F115, F127 & F130)

### FLOW EQUATIONS 5

- EL** = Corrected Liquid Volume (F127)
- EX** = No flow equations (F115 & F130)
- = None on F018

### ENCLOSURE 6

**HE** = Cable Enter: 2-16 mm & 1-20 mm

### ADDITIONAL INPUTS 7

- IR** = Remote control input to start, pause or stop (F130)
- IX** = No additional inputs (F018, F115 & F127)
- = None for F018

### OUTPUTS 8

**OT** = Two passive transistor outputs - standard configuration (F018 only has 1 not 2)

### POWER SUPPLY 9

- PD-PB** = 8 - 24 V (ac/dc) + sensor supply - with XI: 16 - 30 V (dc) & Lithium battery powered (F018\*, F115 & F127)
- PD-PC** = 8 - 24 V (ac/dc) + sensor supply - with XI: 16 - 30 V (dc) & Lithium battery powered - Intrinsically Safe (F018\* & F130)

\*F018 does not have the 8 - 24 V (ac/dc)

### TEMPERATURE INPUT SIGNAL 10

- TP** = PT100 input (F127)
- TX** = No temperature input signal (F115 & F130)
- = None on F018

### HAZARDOUS AREA 11

- XI** = Intrinsically Safe, according to ATEX & IECEx (F018 & F127)
- XX** = Safe area only (F018, F115, & F130)

### OTHER OPTIONS 12

- ZB** = Backlight (F018, F115 & F127)
- ZX** = No options (F130)

1 2 3 4 5 6 7 8 9 10 11 12  
 >>>> F018 P AP CX EX HE IX OT PD-PB TX XX ZB

## SPECIFICATIONS

Display:	
Type	High intensity reflective numeric and alpha-numeric LCD, UV resistant
Dimensions	3.5 in. x 1.6 in. (90 mm x 40 mm)
Digits	Seven 0.67 in. (17 mm) and eleven 0.31 in. (8 mm) digits. Various symbols and measuring units.
Refresh rate	User definable: Fast, 1 s, 3 s, 15 s, 30 s, Off
Option ZB	Transflective LCD with green LED backlight. Good readings in full sunlight and darkness.
Operating Temperature:	
	-40°F to +176°F (-40°C to +80°C)
Power Requirements:	
	8 - 24 V (ac/dc) ± 10%. Power consumption maximum 10 Watt.
	16 - 30V (dc). Power consumption maximum 1 Watt.
Sensor Excitation:	
	1.2 / 3.2 / 8.2 / 12 / 24V (dc) - maximum 400mA @ 24V (dc)
Terminal Connections:	
	Removable plug-in terminal strip. Wire maximum 1.5 mm <sup>2</sup> and 2.5 mm <sup>2</sup>
Data Protection:	
Type:	EEPROM backup of all settings. Backup of running totals every minute. Data retention at least 10 years.
Pass-code:	Configuration settings can be pass-code protected.
Enclosure:	
Dimensions:	5.12" x 4.72" x 2.95" (130 x 120 x 75 mm) W x H x D
Type HE	GRP panel mount enclosure IP65 / NEMA 4X. UV-resistant and flame retardant.
Weight	1.32 lbs (600g)
Environment:	
Electromagnetic compatibility:	Compliant ref: EN 61326 (1997), EN 61010-1 (1993)
Signal Input (Flowmeter):	
	Coil / sine wave (minimum 20mVpp or 80mVpp - sensitivity selectable), NPN / PNP, open collector, reed switch, Namur, active pulse signals 8 - 12 and 24V (dc)
Frequency:	Minimum 0Hz - maximum 7kHz for total and flow rate internal low-pass filter. E.g. reed switch with low-pass filter: maximum frequency 120Hz
K-Factor	0.000010 - 9,999,999 with variable decimal position
Low-pass filter	Available for all pulse signals

## ACCESSORIES

1522056	F-Series Wall Mount Kit
1522052	F-Series Pipe Mount Kit
1519011	M16 Cable Gland Kit
1519012	M20 Cable Gland Kit

Signal Output (Analog):	
Function:	Transmitting differential / sum flow rate
Accuracy:	10 bit. Error < 0.05%. Analog output signal can be scaled to any desired range.
Update time:	Ten times per second
Type AP:	Passive 4-20mA output - not isolated. Unit will be loop powered.
Type AH:	Galvanically isolated, loop powered 4-20mA output
Signal Output (Pulse):	
Function:	Pulse output according to differential or sum accumulated total and indication negative pulse output.
Frequency:	Maximum 64 Hz. Pulse length user definable between 7.8 ms up to 2 seconds
Type OT:	Two passive transistor outputs (NPN) - not isolated. Maximum 50V (dc) - 300mA per output
Communication option:	
Function:	Reading display information, reading / writing all configuration settings
Protocol:	HART
Total - 7 digits, 0 - 1 - 2 or 3 decimals:	
Units:	L, m <sup>3</sup> , GAL, USGAL, kg, lb, bbl, no unit
Note:	Total can be reset to zero
Accumulated Total - 11 digits:	
Units / Decimals:	According to selection for total
Note:	Can not be reset to zero
Flow rate - 7 digits, 0 - 1 - 2 or 3 decimals:	
Units:	mL, m <sup>3</sup> , Gallons, kg, Ton, lb, bl, cf, RND, ft <sup>3</sup> , scf, Nm <sup>3</sup> , NI, ical - no units
Time units:	/s - /min - /hr - /day
Alarm values - 7 digits:	
Units / Decimals:	According to selection for total
Time units:	According to selection for total
Type of alarm:	Low and high flow rate alarm. Includes alarm delay time and configurable alarm outputs.
Line temperature - 6 digits, 1 decimal:	
Units:	°C, °F or K

## DIMENSIONS

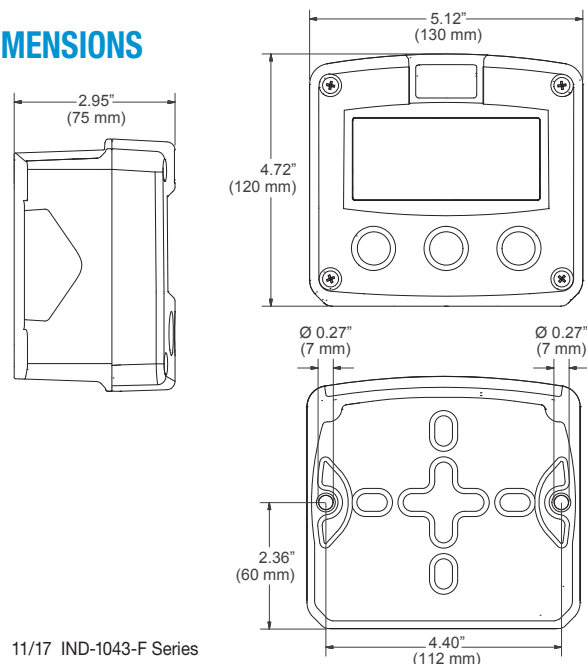

Wichita · Sydney · Mexico City

GREAT PLAINS INDUSTRIES **GPI**

© 2017 Great Plains Industries, Inc. All Rights Reserved.

**Service & Warranty:** For technical assistance, warranty replacement or repair contact your FLOMEC® or GPI® distributor. In North or South America: 888-996-3837 / FLOMEC.net  
Outside North or South America: +61 2 9540 4433 / FLOMEC.net

11/17 IND-1043-F Series





## PRODUCT CONFIGURATION

### PRODUCT IDENTIFIER **1**

**RT14** = Oval Gear Meter

### ELECTRICAL ACCESS **2**

**1** = M20 x 1.5 mm female threaded conduit entry ports

**2** = ½ inch NPT female threaded conduit entry ports

### FLOW INPUT TYPE **3**

**D** = Digital (pulse or frequency)

### POWER SUPPLY **4**

**0** = Self-powered (battery) or regulated 12-30V (dc)

### HOUSING TYPE **5**

**FM** = Universal mount (field or panel) – GRN housing

**MM** = Integral meter mount – GRN housing\*

\* Only order MM when retro fitting an instrument to OM series pulse meters

### ELECTRICAL OPTIONS **6**

**-I** = Intrinsically safe IECEx/ATEX (EXia IIB T4)

--->>>> **1 2 3 4 5 6**  
RT14 1 D 0 FM -I

## RT14 FLOW RATE TOTALIZER

The RT14 is a fully programmable self-powered flow rate totaliser specifically designed for computing and displaying flow rates and totals from flow meters with pulse, sine wave or frequency outputs. The instrument displays resettable (batch) total, accumulated total and instantaneous flow rates in engineering units as programmed by the user. Flow meter inputs: suitable use with most pulse/frequency output meters such as reed switch, coil, voltage pulse (Wiegand), NPN and PNP.

## CONTROL OUTPUTS

Scaled and unscaled pulse outputs allow transmission of accumulated flow data to remote control systems. Flow alarms are available to protect flow systems from flow rates that are 'high', 'low', or both, and an analogue 4-20mA signal offers flow rate monitoring and control by accurately transmitting flow rate readings from the flowmeter to your PLC or PID control system.

## FEATURES / BENEFITS

- Battery, external DC, or loop powered
- Easy to read backlit LCD display
- Robust IP66/67-NEMA4X universal mount glass reinforced nylon enclosure with rubberized buttons and polycarbonate lens
- Large selection of engineering units for flow rate and total
- Ten point linearisation
- 4-20mA analogue output according to flow rate
- Flow alarm for high, low or high/low
- Scaled pulse output according to accumulated total
- Simple flow chart touch key programming
- Non volatile memory, long battery life
- Flowmeter and pipe mount kits available
- Broad operating temperature range

## PROGRAMMING

Simple PIN protected flow chart programming with English prompts guide you through the programming routine greatly reducing the need to refer to the instruction manual.

## SPECIFICATIONS

LCD Display	8 digit alpha-numeric LCD display with 12 mm characters with backlight*
Instantaneous Flow Rate	8 digit to 3 decimal points
Engineering Units Displayed	Liter, mL, Gallon, Quart, Cubic Meter, Pounds, Kilograms or Nil
Input Types	Reed, NPN/PNP, mV sinewave (Turbine flowmeters), Weigand Sensors (voltage pulse)
Input Frequency	1.2 kHz (NPN/PNP), 2 kHz (Coil inputs), 120 kHz (Reed)
Input Scaling Range	0.0001 ~ 9999999.9999 with 4 floating points
Linearisation	10 point correction
Pulse Outputs	One selectable digital output for scaled pulse, unscaled pulse, high, low or high/low alarms
Analogue Output	12 bit 4-20mA ( $\pm 0.05\%$ FS at 25°C)
Operating Temperature	-22°F - +176°F (-30°C - +80°C)
Power Sources	AA 3.6V Lithium Thionyl Chloride Battery, external DC powered or loop powered (12 - 30V (dc))
Enclosures	High impact glass reinforced Nylon (PA6) with a Polycarbonate lens, Nitrile O-Ring seals and Polyurethane gaskets, providing an IP rating of IP66/67 <sup>^</sup>
Mounting	Meter & stem mount, wall, pipe or panel mount <sup>^</sup>
Approvals	Intrinsically Safe - IECEx / ATEX (optional) Ex ia IIB T4 Gb (-30°C <Ta <+70°C)

\* Backlight possible when connected to external power

<sup>^</sup> Panel mount seal kit required to maintain IP66/67 rating when separating front and rear housing for mounting

## ACCESSORIES

1522001	Wall Mount Kit
1522002	2" Pipe Mount Kit
1504003	Panel Mount Seal Kit

## APPROVALS



## DIMENSIONS

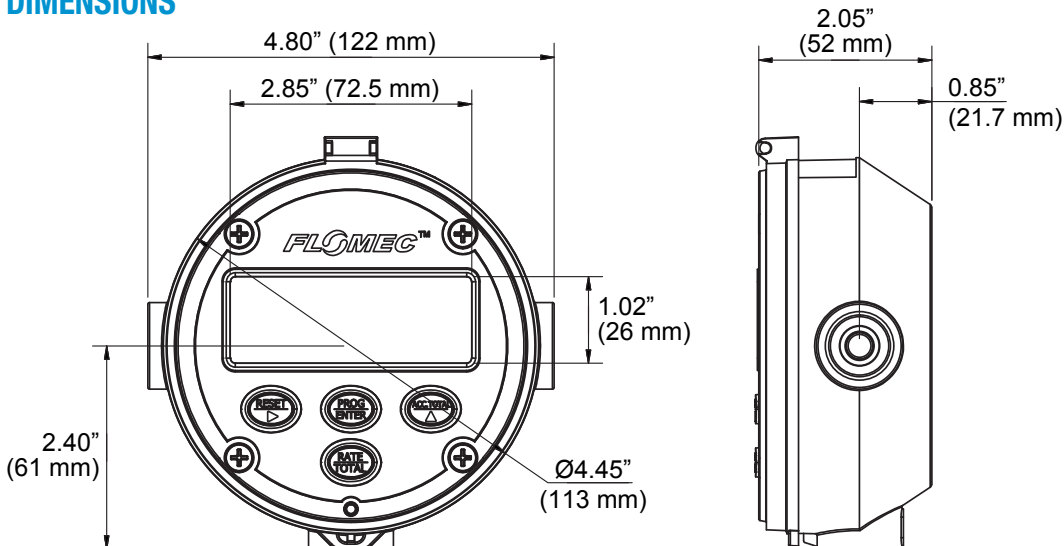

**Service & Warranty:** For technical assistance, warranty replacement or repair contact your FLOMEC® or GPI® distributor: In North or South America: 888-996-3837 / FLOMEC.net  
Outside North or South America: +61 2 9540 4433 / FLOMEC.net

Wichita · Sydney

GREAT PLAINS INDUSTRIES





## PRODUCT CONFIGURATION

### PRODUCT IDENTIFIER 1

**RT40** = Flow Rate Totalizer with backlit large digit LCD, scalable pulse output

### ELECTRICAL ACCESS 2

- 1 = M16 x 1.5mm for Al housing female threaded conduit entry ports (sealed ports remain IP66/67 when not used)
- 6 = 3 x 6mm drilled holes for GRN housing (sealed ports remain IP66/67 when not used)

### FLOW INPUT TYPE 3

**D** = Digital (pulse or frequency)

### POWER SUPPLY 4

**0** = Self-powered (battery) or regulated 8-24 V (dc)

### HOUSING TYPE 5

- FM** = Universal mount (field or panel) - GRN housing
  - FA** = Universal mount (field or panel) - aluminum housing
  - MM** = Integral meter mount - GRN housing\*
  - MA** = Integral meter mount - aluminum housing\*
- \* Only order MA or MM when retro fitting an instrument to OM series pulse meters

1 2 3 4 5  
 ---->>>> RT40 1 D 0 FA

## RT40 FLOW RATE TOTALIZER

The **FLOMEC® RT40 Flow Rate Totalizer** LCD display is specifically designed for displaying flow rates and totals from flow meters with pulse, sine wave or frequency outputs. The instrument displays re-settable (batch) total, cumulative total and instantaneous flow rate in engineering units programmable by the user.

## FEATURES / BENEFITS

- Economic and robust LCD display in a GRN housing
- Robust LCD display suitable for mine sites and service truck installations, in an aluminum housing
- Large backlit\*\* LCD screen displaying 5-digit flow rate, 6-digit resetable total and 8-digit cumulative total
- Battery or externally powered; battery life span is 3 years, approximately\*\*
- Robust IP66/67 (NEMA 4) GRN housing capable of being field or panel mounted
- Robust IP65 (NEMA 4) Aluminum housing capable of being field or panel mounted
- Scaled pulse output\*\*\*
- Universal inputs
- Reverse polarity protection
- Flowmeter and pipe mount kits available
- PIN protected programming with simple programming flow-chart

\*\*External power required for back light or pulse output features.

\*\*\*Max. Output Frequency 20 Hz, K-factor must be divisible by 10.

## SPECIFICATIONS

Display	Large backlit LCD 6-digit display with 8-digit secondary display line
Temperature Range	-4°F - +176°F (-20°C - +80°C)
Signal Input	Reed switch, Hall effect, Namur proximity detectors, voltage, current and coil (15mV P-P min)
Max. Input Frequency	Max. input frequency 5 kHz under external power. Maximum input frequency when not externally powered is 150 Hz
Signal Output	NPN transistor, scalable
Max. Output Frequency	20 Hz
Battery Power	3.6 V (dc), approximate 3 year life span
External Power	Regulated 8-24 V (dc) x 50 mA minimum
Protection Class & Body	IP65 (NEMA 4) Aluminium housing IP66/67 (NEMA 4) GRN housing
Mounting	Field, meter or panel mount
Engineering Units	Selectable Ltr, gal, m <sup>3</sup> , kgs, lbs (total). /s, /min, /hr or /day (rate)
Cable Entries	3 x M16 x 1.5, Aluminum housing 3 x 6mm drilled, GRN housing

## DIMENSIONS

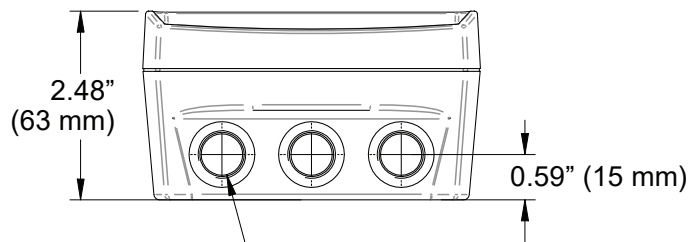
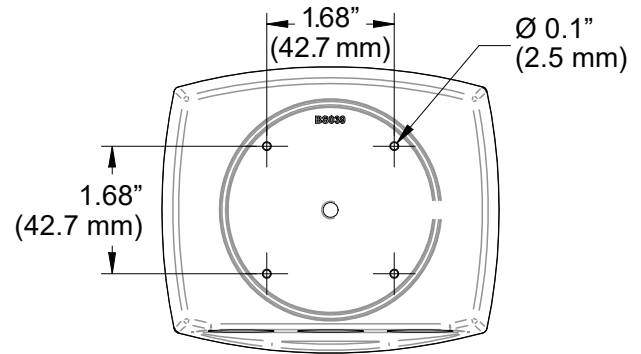
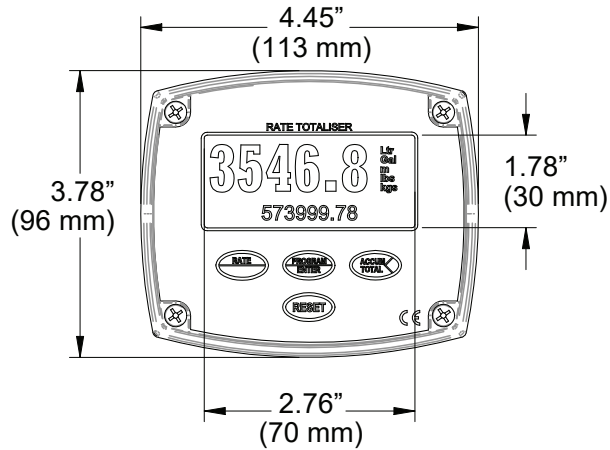

3 Conduit Entries  
M16 x 1.5 (Aluminum)  
or  
16mm Drilled Holes (GRN)

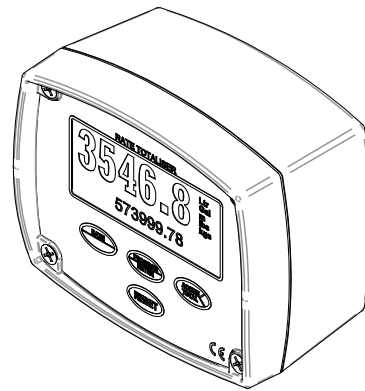

**Service & Warranty:** For technical assistance, warranty replacement or repair contact your **FLOMEC®** or **GPI®** distributor: In North or South America: **888-996-3837 / FLOMEC.net**  
Outside North or South America: **+61 2 9540 4433 / FLOMEC.net**

Wichita · Sydney

GREAT PLAINS INDUSTRIES

