



PRODUCT CONFIGURATION

OM SERIES SMALL CAPACITY (OVAL GEAR METERS)

The **FLOMEC® OM Small Capacity Oval Gear Meters** have a large flow range and offer the ability to handle a wide range of fluid viscosities with exceptional levels of repeatability.

FEATURES / BENEFITS

- High accuracy and repeatability, direct volumetric reading
- Measures high and low viscosity liquids
- No requirement for flow conditioning (straight pipe runs)
- Stainless Steel rotors (Optional PPS rotor for OM008 meter only)
- Quadrature pulse output option and bi-directional flow
- Optional Exd I/IB approval (ATEX, IECEx)
- Only two moving parts

PRODUCT IDENTIFIER **1**

OM = Oval Gear Meter

METER SIZE **2**

004 = 1/8" (4 mm), 0.26-9.5 GPH (1.0-36 L/hr)

006 = 1/4" (6 mm), 0.5-27 GPH (2-100 L/hr)

008 = 3/8" (8 mm), 4-145 GPH (15-550 L/hr)

BODY MATERIAL **3**

A = Aluminum

S = 316 Stainless Steel

N = Intermediate Pressure 316L SS (1450 PSI / 100 bar)

ROTOR MATERIAL / BEARING TYPE **4**

00 = PPS (Not available for 300° F (150° C) meters) / No bearing (Available for OM008 only)

51 = Stainless Steel / Carbon Ceramic (Standard on OM004 & OM006, optional for OM008)

71 = Keishi cut Stainless Steel (For high viscosity liquids) / Carbon Ceramic (Available for OM008 only)

O-RING MATERIAL **5**

1 = FKM (Viton™) -5° F minimum (-15° C)

3 = PTFE encapsulated FKM (Viton™) 5° F minimum (-15° C)

4 = Buna-N (Nitrile), -40° F minimum (-40° C)

MAXIMUM TEMPERATURE LIMIT **6**

-2 = 250° F (120° C) max.

-3 = 300° F (150° C) max. (Hall Effect)(Includes Stainless Steel terminal cover)

-5 = 250° F (120° C) max. (includes integral cooling fin)

-8 = 176° F (80° C) max. (meters with integral instruments, OM008 with PPS rotors)

PROCESS CONNECTIONS **7**

1 = BSPP (G) female threaded (ISO 228)

2 = NPT female threaded

B = Bottom entry manifold (SS body only)

CABLE ENTRIES **8**

1 = M20 x 1.5 mm (M16 x 1.5 mm for R4 options)

2 = 1/2" NPT

6 = 3 x 16mm drilled holes (for F instruments only)

INTEGRAL OPTIONS **9**

__ = Combination Reed Switch and Hall Effect Sensor

SS = Stainless Steel terminal cover

RS = Reed Switch only - to suit Intrinsically safe installations

E1 = Explosion proof Exd IIB T3...T6 (Aluminum & Stainless Steel meters) [IECEx & ATEX approved]

E2 = Explosion proof Exd I/IB T3...T6 (Stainless Steel meters only) [IECEx & ATEX mines approved]

QP = Quadrature pulse (2 NPN phased outputs)

Q1 = Explosion proof ~ Exd (with quadrature pulse) [IECEx & ATEX approved]

HR = High Resolution Hall Effect output (004 – 006 only)

H1 = Explosion proof ~ Exd with HR Hi-Res. Hall option (004-006 only)

R3 = RT12 Intrinsically Safe rate totalizer with all outputs (GRN Housing) [IECEx & ATEX approved]*#

R3G = RT12 Intrinsically Safe rate totalizer with all outputs (GRN Housing) [IECEx & ATEX approved] (with gallons calibration)*#

R4 = RT40 rate totalizer with backlit large digit LCD (Alloy housings with facia)*#

R4G = RT40 rate totalizer with backlit large digit LCD (Alloy housings with facia) (with gallons calibration)*#

R5 = RT14 backlit rate totalizer with all outputs (GRN Housing)*#

R5G = RT14 backlit rate totalizer with all outputs (GRN Housing) (with gallons calibration)*#

E18 = E018 backlit rate/tot, pulse, 4-20mA, 10 point linearization, HART, aluminium body [IECEx & ATEX approved]#

E19 = E018 backlit rate/tot, pulse, 4-20mA, 10 point linearization, HART, stainless steel body [IECEx & ATEX approved]#

F18 = F018 backlit rate/tot, pulse, 4-20mA, 10 point linearization, HART#

F19 = F018 backlit rate/tot, pulse, 4-20mA, 10 point linearization, HART, Intrinsically safe# [IECEx & ATEX approved]

F31 = Intrinsically safe F130 2 stage batch controller# [IECEx & ATEX approved]

*Temp code 5 required for integral instruments between 176°F (80°C) & 250°F (120°C)

#Temp code 8 required for integral instruments below 176°F (80°C)

SPECIFICATIONS

	OM004	OM006	OM008
Nominal Size:	1/8" (4 mm)	1/4" (6 mm)	3/8" (8 mm)
Flow* Range:	0.26-9.5 GPH (1.0-36 L/hr)	0.5-27 GPH (2-100 L/hr)	4-145 GPH (15-550 L/hr)
Accuracy* @ 3cp:	± 1.0% of reading (accuracy is ± 0.2% of reading with optional RT14 with non-linearity correction)		
Repeatability:	Typically ± 0.03% of reading		
Temperature Range:	-40° F to +300° F (-40° C to +150° C)		
Pressure Rating (Threaded Meter):			
Aluminum	220 psi (15 bar)		
316 Stainless Steel	495 psi (34 bar)		
Intermediate Pressure Stainless Steel	1450 psi (100 bar)		
Recommended Filtration:	200 mesh (75 µm)		

	OM004	OM006	OM008
Electrical:			
Output Pulse Resolution:	Pulses / gallon (Pulses / L) - Nominal		
Reed Switch	10600 (2800)	3975 (1050)	1345 (355)
Hall Effect	10600 (2800)	3975 (1050)	2690 (710)
QP - Quadrature Hall option	10600 (2800)	3975 (1050)	2690 (710)
HR - High Resolution Hall Effect	42400 (11200)	15900 (4200)	n/a
Reed Switch Output	30V (dc) x 200mA max. [maximum thermal shock 18° F (10° C) / minute]		
Hall Effect Output (NPN)	3 wire open collector, 5-24V (dc) max., 20mA max.		
Optional Outputs	4-20mA, scaled pulse, quadrature pulse, flow alarms or two stage batch control		

*Maximum flow is to be reduced as viscosity increases, see flow de-rating guide. Max recommended pressure drop is 14.5 psi (1 bar).
*When used to meter rate, at very low flow rates, the rate can jump, due to resolution (not accuracy).

DIMENSIONS

OPTION	B			C
	OM004	OM006	OM008	—
RT12 / RT14 GRN HOUSING	4.8" (122 mm)	4.8" (122 mm)	5.0" (129 mm)	4.9" (124 mm)
RT40	4.9" (125 mm)	4.9" (125 mm)	5.2" (132 mm)	3.8" (96 mm)
COVER	3.6" (92 mm)	3.6" (92 mm)	3.9" (99 mm)	2.8" (72 mm)

*All dimensions are ± .079" (±2mm)

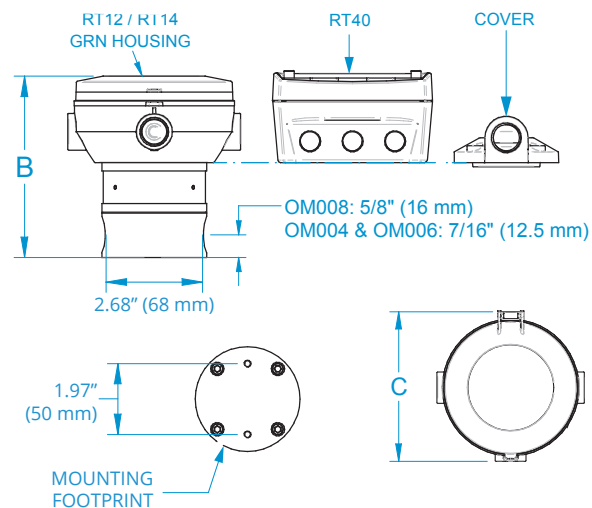

APPLICATIONS

- Oils
- Fuel
- Diesel
- Truck Metering
- Chemical Additive Injection
- Batching
- Molasses
- Clean Fluids
- Bunker C Fuel Oil
- Oil-Based Paints
- Industrial Fluids
- Chemical Feed Lines

APPROVALS



IP66/67

Service & Warranty: For technical assistance, warranty replacement or repair contact your **FLOMEC®** or **GPI®** distributor. In North or South America: **888-996-3837 / FLOMEC.net**
Outside North or South America: **+61 2 9540 4433 / FLOMEC.net**



E SERIES EXPLOSION PROOF TOTALIZER & FLOW RATE INDICATOR

BENEFITS

- Save time with the easy-to-operate through glass keypad: no need to remove the front cover nor to arrange a work permit
- Easy installation with the spacious chamber and plug and play connectors
- Long life duration in extremely salty atmospheres (offshore) with heavy duty stainless steel Exd enclosure
- Key information at a glance as the display shows flow rate, total, measuring units and a flow rate indicating speedometer

FEATURES

- Selectable on-screen engineering units; volumetric or mass
- 7 digit flow rate / total and 11 digit accumulated total
- 16 point linearization of the flow curve - with interpolation
- Power options: Loop powered, battery and 8 - 30V (dc)
- Isolated, loop powered 4 - 20mA output according to linearized flow rate
- Scaled pulse output according to linearized accumulated total
- Ability to process all types of volumetric or mass flowmeter signals: Reed-switch, NAMUR, NPN/PNP pulse, Sine wave (coil), Active pulse signals. (0)4 - 20mA and 0 - 10V (dc) analog inputs are pending.
- HART communication

APPLICATIONS

The E018 by FLOMEC[®] offers you an enclosure designed to be used in rough and tough applications, beyond being just explosion proof. Its sturdy design and ease of use are unequalled by any other explosion proof indicator in the market. The E018 is always your first and safest choice in explosion proof applications.

PRODUCT CONFIGURATION

STANDARD CONFIGURATION 1

E018 = Flow Rate Monitor / Totalizer - Alarms - HART

FLOWMETER INPUT SIGNAL 2

P = Pulse input: Coil, NPN, PNP, Namur, Reed-switch

ANALOG OUTPUT SIGNAL 3

AH = Galvanically isolated, Loop powered 4-20mA output

COMMUNICATION 4

CR = HART communication

ENCLOSURE TYPES 5

HAD = Diecast Aluminum Enclosure, Entry threads: 2" x 1/2" NPT / 1" x 3/4" NPT

HSD = Stainless Steel Enclosure, Entry threads: 2" x 1/2" NPT / 1" X 3/4" NPT

ADDITIONAL INPUTS 6

IB = Remote input to reset total or to lock the "Clear Total" button

OUTPUTS 7

OT = Passive transistor output - standard configuration

POWER REQUIREMENTS 8

PD-PB = 9 - 27 V (dc) + sensor supply, Lithium battery power

HAZARDOUS AREA 9

XD = Explosion proof enclosure according ATEX & IECEx (CSA and FM Pending)

OTHER OPTIONS 10

ZB = Backlight is included as standard

1 2 3 4 5 6 7 8 9 10
 >>>> E112 P AH CX HAA IB OT PX-PB XD ZB

SPECIFICATIONS

Display:	
Type	High intensity transreflective numeric and alpha-numeric LCD, UV resistant, with bright backlight. Intensity can be adjusted via keypad.
Digits	Seven 0.47" (12 mm) and eleven 0.28" (7 mm) digits. Various symbols and measuring units.
Refresh rate	User definable: 8 times/s to 30 s.
Speedometer	To indicate the actual flow rate the bargraph runs from 0 to 100% in 20 blocks, each block is 5%.

Operating Temperature (Operational):	
-40°F to +158°F (-40°C to +70°C)	

Power Requirements:	
9 - 27V (dc). Power consumption maximum 4.2 Watt. Long life Lithium battery - lifetime depends upon settings and configuration - up to approximately 2 years	

Hazardous Area - Explosion Proof:	
ATEX Certification:	Ex II 2 G Ex IIC T6 Gb Ex II 2 D Ex IIIC T85°C Db
IECEX Certification	Ex d IIC T6 Gb Ex tb IIIC T85°C Db
FM / CSA c-us Certification	Explosion-proof for use in Class I, Division 1, Groups A, B, C, D DIP (Dust-Ignition-proof): Class II, Division 1, Groups E, F and G. Class III, hazardous (classified) locations
Ambient to:	-40°F to +158°F (-40°C to +70°C)

Hazardous Area - Directives:	
EMC:	Compliant ref. EN61326-1 and FCC 47 CFR part 15
Low voltage:	Compliant ref. EN61010-1

Signal Input (Flowmeter):	
	Coil / sine wave (COIL-HI: 20mVpp or COIL-LO: 80mVpp - sensitivity selectable), NPN / PNP, open collector, reed switch, Namur, active pulse signals 8 - 12 and 24V (dc)
Frequency:	Minimum 0Hz - maximum 7 kHz for total and flow rate. Maximum frequency depends on signal type and internal low-pass filter. E.g. reed switch with low-pass filter. Maximum frequency 120Hz.
K-Factor	0.000010 - 9,999,999 with variable decimal position
Low-pass filter	Available for all pulse signals

External Reset Total:	
Function:	<ul style="list-style-type: none"> Terminal input to reset total remotely If this terminal input is closed, the "clear total" function is disabled
Type:	Internally pulled-up switch contact - NPN
Duration:	Minimum pulse duration 100ms

Signal Output (Digital):	
Function:	Pulse output. Transmitting accumulated total
Frequency:	Maximum 500Hz. Pulse length user definable between 1 ms up to 10 seconds
Type OT:	One passive transistor output (NPN) - not isolated. 300mA - 50V @ 77°F (25°C)

Signal Output (Analog):	
Function:	Transmitting linearized flow rate
Accuracy:	12 bit. Error < 0.1%. Analog output signal can be scaled to any desired range.
Type AH:	Galvanically isolated, loop powered 4-20mA output

Accumulated Total - 11 digits:	
Units / Decimals:	According to selection for total
Note:	Can not be reset to zero

Flow rate - 7 digits, 0 - 1 - 2 or 3 decimals:	
Units:	mL, L, m³, Gallons, kg, Ton, lb, bl, cf, RND, ft³, scf, Nm³, NI, ical - no units
Time units:	/s - /min - /hr - /day

ACCESSORIES

Part No.	Description
FW-ABB04	1 X 3/4 inch NPT plug
FW-ABB05	1 X 1 inch NPT plug
1522068	E-Series Wall Mount Kit
1522051	E-Series Pipe Mount Kit

APPROVALS



DIMENSIONS

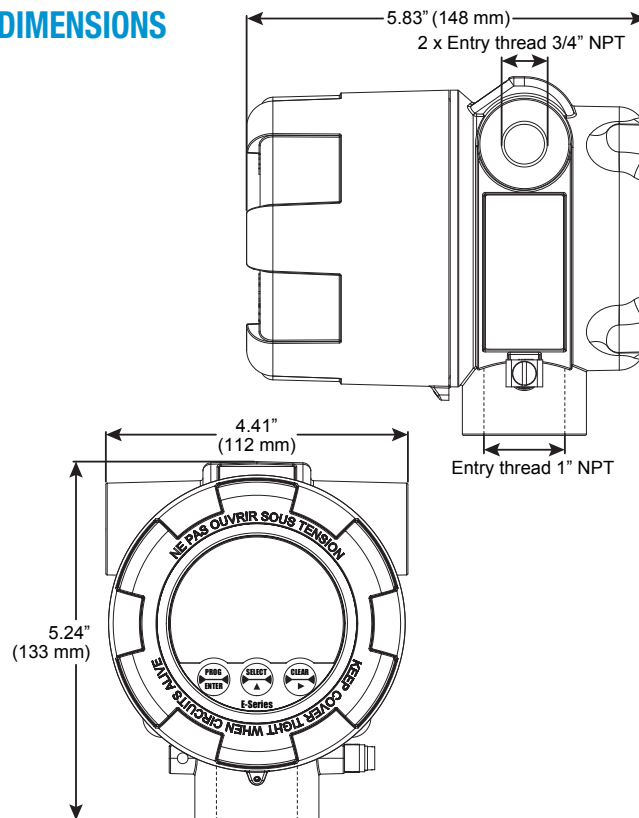

Service & Warranty: For technical assistance, warranty replacement or repair contact your FLOMEC® or GPI® distributor: In North or South America: 888-996-3837 / FLOMEC.net
Outside North or South America: +61 2 9540 4433 / FLOMEC.net



EB11 'EasyBatch' CONTROLLER

The FLOMEC EB11 “EasyBatch” is a dual stage batch controller designed to create an efficient and accurate dispensing experience. Mountable either directly onto a FLOMEC® flow meter or remotely, and compatible with multiple types of industry signals, the EB11 allows the user to control the volume of fluid dispensed into their process, while the large 7-digit display with back light enables easy reading of the batch status in either light or dark conditions. Housed in an IP66/67-NEMA4X rated Glass Reinforced Nylon enclosure for increased impact and corrosion resistance, particularly in washdown environments. The EB11 contains 2 digital NPN outputs with a current rating of up to 300mA for direct control of solenoid valves, or to connect to relays to allow for the control of large valves and pumps.

FEATURES

- Easy to use 2 button controller
- Weather resistant and durable IP66/67 - NEMA4X enclosure
- Easy to read backlit 7-digit display
- Retained settings after power loss

PRODUCT CONFIGURATION

PRODUCT IDENTIFIER **1**

EB11 = EasyBatch dc powered dual stage batch controller

ELECTRICAL ACCESS **2**

1 = M20 x 1.5 mm female threaded conduit entry ports (sealed ports remain IP66/67 when not used)

2 = 1/2 in. NPT female threaded conduit entry ports

FLOW INPUT TYPE **3**

D = Digital (pulse or frequency)

POWER SUPPLY **4**

0 = Self-powered (battery) or regulated 8-24v (dc)

HOUSING TYPE **5**

FM = Universal mount (field or panel) - GRN housing

MM = Integral meter mount - GRN housing*

*MM when retrofitting an instrument to OM series pulse meters

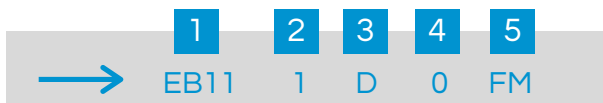

ACCESSORIES (for above series)

1522001	Stainless steel wall mount kit
1522002	Stainless steel 2 in. pipe mount kit
1502015	Cooling fin kit for flow meters with integral instruments (for operating between 60°C [140°F] and 100°C [212°F])
1322039	ADM M20-M16 metric adapter
1319006	M16 cable gland
1511002	6-core screened instrument cable

SPECIFICATIONS

Display	12 mm 7-digit batch total and 7 mm 7-digit batch preset
Engineering Units	Liters, gallons, m ³ , lbs, kgs, or no engineering units
Input Types & Max Frequency	Namur (4kHz), Reed-switch (120 Hz), NPN (6kHz), PNP (6kHz) and coil.
Control Outputs	GRN housing: 2x 300mA NPN Open Collectors, 24v (dc)
Operating Temperature	Field Mount: -10°C - +60°C (14°F - +140°F)
Enclosures	Field Mount: GRN Housing, IP66 (NEMA4X)
Power Requirements	Field Mount: 10-30v (dc)
Mounting Options	Meter or stem mount, wall, surface, pipe or panel mount*

**Panel mount seal kit required to maintain IP66/67 rating when separating from rear housing for mounting when using GRN housing.*

DIMENSIONS / FIELD MOUNT

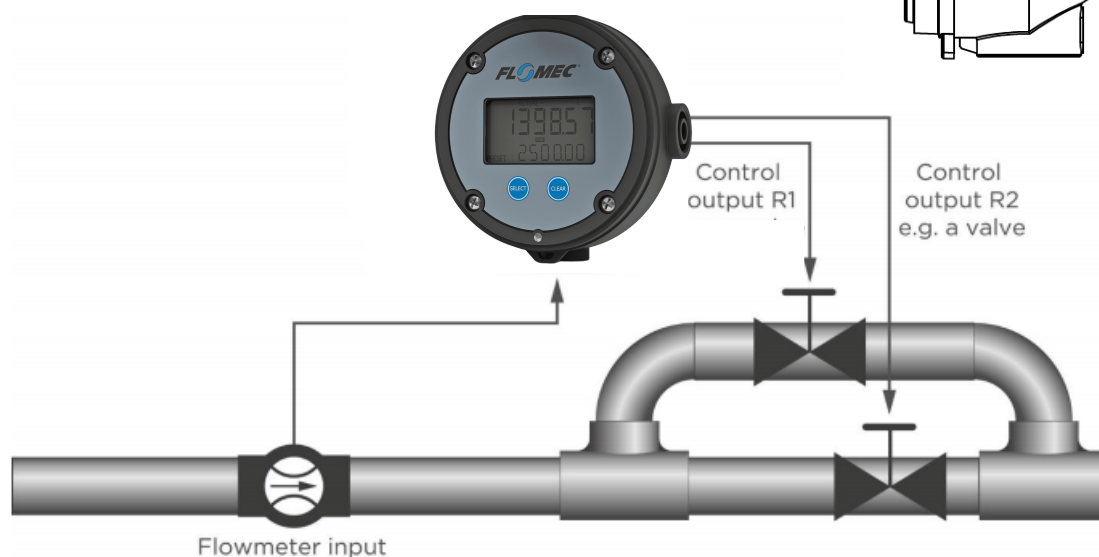
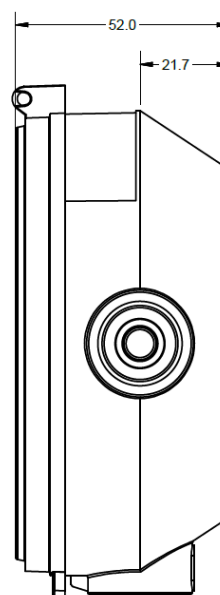
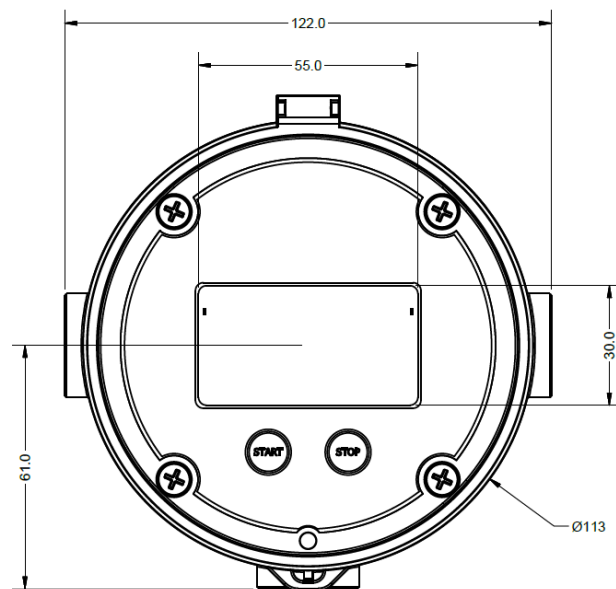



F SERIES (REMOTE PANEL MOUNT ELECTRONICS)

Top of the line specialty electronics by **FLOMEC® F Series Electronics** are designed with several different input and output options. Rugged and dependable, the F Series offers:

- Field-mountable
- Easy programming with a sensible menu-driven structure
- Large 0.67" (17 mm), 7 digit display
- Accepts several different input signals

FEATURES / BENEFITS

- Batching
- Net Use
- 4-20 mA Output
- HART Protocol
- High Low Alarms
- Linearization
- Two Stage Valve Control
- Temperature Compensation

APPLICATIONS

- The F-Series is your first and safest choice for fieldmount indicators. Especially in harsh weather conditions like rain, snow, salty atmospheres and temperatures between -40°F up to +176°F (-40°C up to 80°C) for safe and hazardous area applications.
- Applications where net flow calculation at base conditions is desired without the influence of thermal product expansion.
- Liquid flow measurement with mechanical flowmeters where a precise calculation over the full measurement range is required. Also continuous flow rate monitoring is required.
- For batching small up to very large quantities. Single or repeating batches.
- Fuel consumption calculation for diesel engines on board of ships or trains. Sum function: where flows are split-up in two pipe-lines and total flow has to be calculated.

APPROVALS

IECEX



PRODUCT CONFIGURATION

STANDARD CONFIGURATION 1

- F018** = Flow Rate Monitor / Totalizer - Linearization & Alarms
- F115** = Flow Rate Monitor / Totalizer - Bi-Directional - Quadrature
- F127** = Differential / Sum Flow Computer - Net Use - Temp Correction
- F130** = Batch Controller - Two Stage

FLOWMETER INPUT SIGNAL 2

P = Pulse input: Coil, NPN, PNP, Namur, Reed-switch

ANALOG OUTPUT SIGNAL 3

- AP** = Passive 4-20mA output, loop powered unit (F115 & F127)
- AH** = Galvanically isolated, loop powered 4-20 mA output (F018)
- AX** = No analog output (F130)

COMMUNICATION 4

- CR** = HART Communication (F018)
- CX** = NO communications (F115, F127 & F130)

FLOW EQUATIONS 5

- EL** = Corrected Liquid Volume (F127)
- EX** = No flow equations (F115 & F130)
- = None on F018

ENCLOSURE 6

HE = Cable Enter: 2-16 mm & 1-20 mm

ADDITIONAL INPUTS 7

- IR** = Remote control input to start, pause or stop (F130)
- IX** = No additional inputs (F018, F115 & F127)
- = None for F018

OUTPUTS 8

OT = Two passive transistor outputs - standard configuration (F018 only has 1 not 2)

POWER SUPPLY 9

- PD-PB** = 8 - 24 V (ac/dc) + sensor supply - with XI: 16 - 30 V (dc) & Lithium battery powered (F018*, F115 & F127)
- PD-PC** = 8 - 24 V (ac/dc) + sensor supply - with XI: 16 - 30 V (dc) & Lithium battery powered - Intrinsically Safe (F018* & F130)

*F018 does not have the 8 - 24 V (ac/dc)

TEMPERATURE INPUT SIGNAL 10

- TP** = PT100 input (F127)
- TX** = No temperature input signal (F115 & F130)
- = None on F018

HAZARDOUS AREA 11

- XI** = Intrinsically Safe, according to ATEX & IECEx (F018 & F127)
- XX** = Safe area only (F018, F115, & F130)

OTHER OPTIONS 12

- ZB** = Backlight (F018, F115 & F127)
- ZX** = No options (F130)

1 2 3 4 5 6 7 8 9 10 11 12
 >>>> F018 P AP CX EX HE IX OT PD-PB TX XX ZB

SPECIFICATIONS

Display:	
Type	High intensity reflective numeric and alpha-numeric LCD, UV resistant
Dimensions	3.5 in. x 1.6 in. (90 mm x 40 mm)
Digits	Seven 0.67 in. (17 mm) and eleven 0.31 in. (8 mm) digits. Various symbols and measuring units.
Refresh rate	User definable: Fast, 1 s, 3 s, 15 s, 30 s, Off
Option ZB	Transflective LCD with green LED backlight. Good readings in full sunlight and darkness.
Operating Temperature:	
	-40°F to +176°F (-40°C to +80°C)
Power Requirements:	
	8 - 24 V (ac/dc) ± 10%. Power consumption maximum 10 Watt.
	16 - 30V (dc). Power consumption maximum 1 Watt.
Sensor Excitation:	
	1.2 / 3.2 / 8.2 / 12 / 24V (dc) - maximum 400mA @ 24V (dc)
Terminal Connections:	
	Removable plug-in terminal strip. Wire maximum 1.5 mm ² and 2.5 mm ²
Data Protection:	
Type:	EEPROM backup of all settings. Backup of running totals every minute. Data retention at least 10 years.
Pass-code:	Configuration settings can be pass-code protected.
Enclosure:	
Dimensions:	5.12" x 4.72" x 2.95" (130 x 120 x 75 mm) W x H x D
Type HE	GRP panel mount enclosure IP65 / NEMA 4X. UV-resistant and flame retardant.
Weight	1.32 lbs (600g)
Environment:	
Electromagnetic compatibility:	Compliant ref: EN 61326 (1997), EN 61010-1 (1993)
Signal Input (Flowmeter):	
	Coil / sine wave (minimum 20mVpp or 80mVpp - sensitivity selectable), NPN / PNP, open collector, reed switch, Namur, active pulse signals 8 - 12 and 24V (dc)
Frequency:	Minimum 0Hz - maximum 7kHz for total and flow rate internal low-pass filter. E.g. reed switch with low-pass filter: maximum frequency 120Hz
K-Factor	0.000010 - 9,999,999 with variable decimal position
Low-pass filter	Available for all pulse signals

ACCESSORIES

1522056	F-Series Wall Mount Kit
1522052	F-Series Pipe Mount Kit
1519011	M16 Cable Gland Kit
1519012	M20 Cable Gland Kit

Signal Output (Analog):	
Function:	Transmitting differential / sum flow rate
Accuracy:	10 bit. Error < 0.05%. Analog output signal can be scaled to any desired range.
Update time:	Ten times per second
Type AP:	Passive 4-20mA output - not isolated. Unit will be loop powered.
Type AH:	Galvanically isolated, loop powered 4-20mA output
Signal Output (Pulse):	
Function:	Pulse output according to differential or sum accumulated total and indication negative pulse output.
Frequency:	Maximum 64 Hz. Pulse length user definable between 7.8 ms up to 2 seconds
Type OT:	Two passive transistor outputs (NPN) - not isolated. Maximum 50V (dc) - 300mA per output
Communication option:	
Function:	Reading display information, reading / writing all configuration settings
Protocol:	HART
Total - 7 digits, 0 - 1 - 2 or 3 decimals:	
Units:	L, m ³ , GAL, USGAL, kg, lb, bbl, no unit
Note:	Total can be reset to zero
Accumulated Total - 11 digits:	
Units / Decimals:	According to selection for total
Note:	Can not be reset to zero
Flow rate - 7 digits, 0 - 1 - 2 or 3 decimals:	
Units:	mL, m ³ , Gallons, kg, Ton, lb, bl, cf, RND, ft ³ , scf, Nm ³ , NI, ical - no units
Time units:	/s - /min - /hr - /day
Alarm values - 7 digits:	
Units / Decimals:	According to selection for total
Time units:	According to selection for total
Type of alarm:	Low and high flow rate alarm. Includes alarm delay time and configurable alarm outputs.
Line temperature - 6 digits, 1 decimal:	
Units:	°C, °F or K

DIMENSIONS

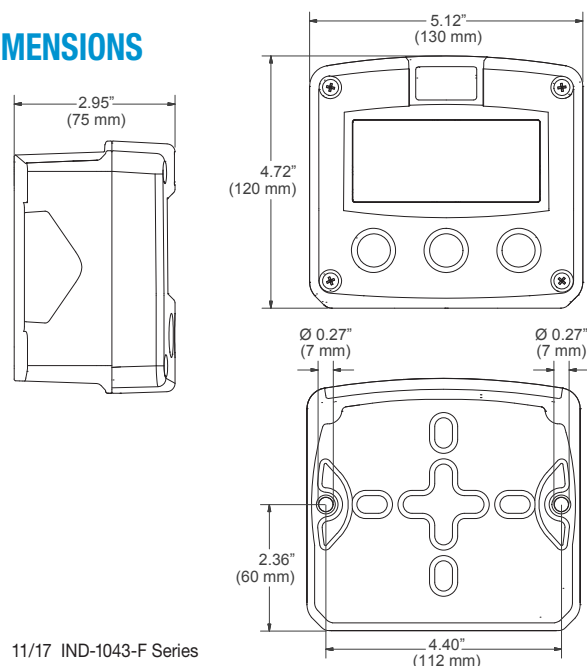

Wichita · Sydney · Mexico City

GREAT PLAINS INDUSTRIES **GPI**

© 2017 Great Plains Industries, Inc. All Rights Reserved.

Service & Warranty: For technical assistance, warranty replacement or repair contact your **FLOMEC**® or **GPI**® distributor: In North or South America: **888-996-3837 / FLOMEC.net**
Outside North or South America: **+61 2 9540 4433 / FLOMEC.net**

11/17 IND-1043-F Series



PRODUCT CONFIGURATION

PRODUCT IDENTIFIER **1**

RT14 = Oval Gear Meter

ELECTRICAL ACCESS **2**

1 = M20 x 1.5 mm female threaded conduit entry ports

2 = ½ inch NPT female threaded conduit entry ports

FLOW INPUT TYPE **3**

D = Digital (pulse or frequency)

POWER SUPPLY **4**

0 = Self-powered (battery) or regulated 12-30V (dc)

HOUSING TYPE **5**

FM = Universal mount (field or panel) – GRN housing

MM = Integral meter mount – GRN housing*

* Only order MM when retro fitting an instrument to OM series pulse meters

ELECTRICAL OPTIONS **6**

-I = Intrinsically safe IECEx/ATEX (EXia IIB T4)

--->>>> **1 2 3 4 5 6**
RT14 1 D 0 FM -I

RT14 FLOW RATE TOTALIZER

The RT14 is a fully programmable self-powered flow rate totaliser specifically designed for computing and displaying flow rates and totals from flow meters with pulse, sine wave or frequency outputs. The instrument displays resettable (batch) total, accumulated total and instantaneous flow rates in engineering units as programmed by the user. Flow meter inputs: suitable use with most pulse/frequency output meters such as reed switch, coil, voltage pulse (Wiegand), NPN and PNP.

CONTROL OUTPUTS

Scaled and unscaled pulse outputs allow transmission of accumulated flow data to remote control systems. Flow alarms are available to protect flow systems from flow rates that are 'high', 'low', or both, and an analogue 4-20mA signal offers flow rate monitoring and control by accurately transmitting flow rate readings from the flowmeter to your PLC or PID control system.

FEATURES / BENEFITS

- Battery, external DC, or loop powered
- Easy to read backlit LCD display
- Robust IP66/67-NEMA4X universal mount glass reinforced nylon enclosure with rubberized buttons and polycarbonate lens
- Large selection of engineering units for flow rate and total
- Ten point linearisation
- 4-20mA analogue output according to flow rate
- Flow alarm for high, low or high/low
- Scaled pulse output according to accumulated total
- Simple flow chart touch key programming
- Non volatile memory, long battery life
- Flowmeter and pipe mount kits available
- Broad operating temperature range

PROGRAMMING

Simple PIN protected flow chart programming with English prompts guide you through the programming routine greatly reducing the need to refer to the instruction manual.

SPECIFICATIONS

LCD Display	8 digit alpha-numeric LCD display with 12 mm characters with backlight*
Instantaneous Flow Rate	8 digit to 3 decimal points
Engineering Units Displayed	Liter, mL, Gallon, Quart, Cubic Meter, Pounds, Kilograms or Nil
Input Types	Reed, NPN/PNP, mV sinewave (Turbine flowmeters), Weigand Sensors (voltage pulse)
Input Frequency	1.2 kHz (NPN/PNP), 2 kHz (Coil inputs), 120 kHz (Reed)
Input Scaling Range	0.0001 ~ 9999999.9999 with 4 floating points
Linearisation	10 point correction
Pulse Outputs	One selectable digital output for scaled pulse, unscaled pulse, high, low or high/low alarms
Analogue Output	12 bit 4-20mA ($\pm 0.05\%$ FS at 25°C)
Operating Temperature	-22°F - +176°F (-30°C - +80°C)
Power Sources	AA 3.6V Lithium Thionyl Chloride Battery, external DC powered or loop powered (12 - 30V (dc))
Enclosures	High impact glass reinforced Nylon (PA6) with a Polycarbonate lens, Nitrile O-Ring seals and Polyurethane gaskets, providing an IP rating of IP66/67^
Mounting	Meter & stem mount, wall, pipe or panel mount^
Approvals	Intrinsically Safe - IECEx / ATEX (optional) Ex ia IIB T4 Gb (-30°C <Ta <+70°C)

* Backlight possible when connected to external power

^ Panel mount seal kit required to maintain IP66/67 rating when separating front and rear housing for mounting

ACCESSORIES

1522001	Wall Mount Kit
1522002	2" Pipe Mount Kit
1504003	Panel Mount Seal Kit

APPROVALS



DIMENSIONS

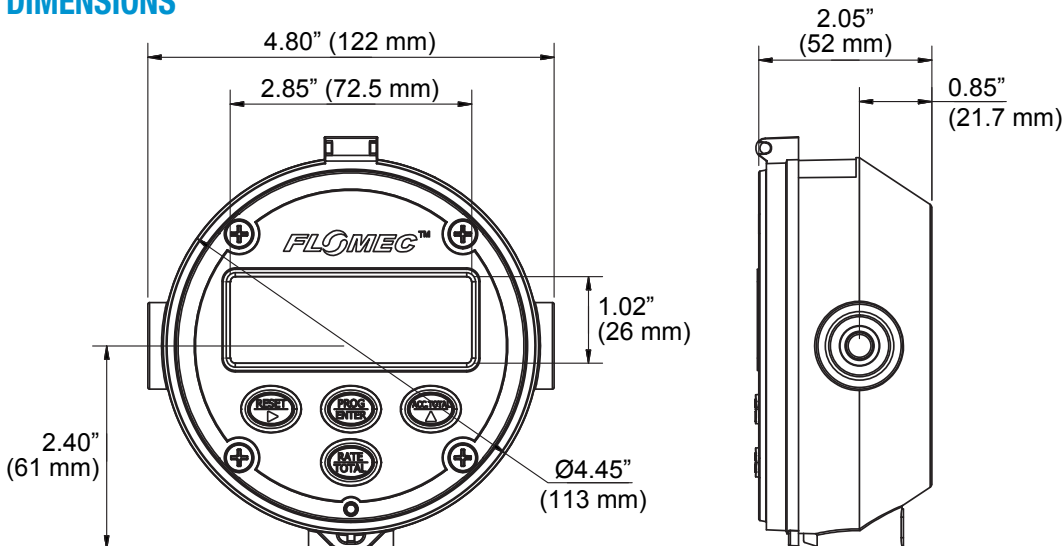

Service & Warranty: For technical assistance, warranty replacement or repair contact your FLOMEC® or GPI® distributor: In North or South America: 888-996-3837 / FLOMEC.net
Outside North or South America: +61 2 9540 4433 / FLOMEC.net

Wichita · Sydney

GREAT PLAINS INDUSTRIES





PRODUCT CONFIGURATION

PRODUCT IDENTIFIER 1

RT40 = Flow Rate Totalizer with backlit large digit LCD, scalable pulse output

ELECTRICAL ACCESS 2

- 1 = M16 x 1.5mm for Al housing female threaded conduit entry ports (sealed ports remain IP66/67 when not used)
- 6 = 3 x 6mm drilled holes for GRN housing (sealed ports remain IP66/67 when not used)

FLOW INPUT TYPE 3

D = Digital (pulse or frequency)

POWER SUPPLY 4

0 = Self-powered (battery) or regulated 8-24 V (dc)

HOUSING TYPE 5

- FM** = Universal mount (field or panel) - GRN housing
 - FA** = Universal mount (field or panel) - aluminum housing
 - MM** = Integral meter mount - GRN housing*
 - MA** = Integral meter mount - aluminum housing*
- * Only order MA or MM when retro fitting an instrument to OM series pulse meters

1 2 3 4 5
 ---->>>> RT40 1 D 0 FA

RT40 FLOW RATE TOTALIZER

The **FLOMEC® RT40 Flow Rate Totalizer** LCD display is specifically designed for displaying flow rates and totals from flow meters with pulse, sine wave or frequency outputs. The instrument displays re-settable (batch) total, cumulative total and instantaneous flow rate in engineering units programmable by the user.

FEATURES / BENEFITS

- Economic and robust LCD display in a GRN housing
- Robust LCD display suitable for mine sites and service truck installations, in an aluminum housing
- Large backlit** LCD screen displaying 5-digit flow rate, 6-digit resetable total and 8-digit cumulative total
- Battery or externally powered; battery life span is 3 years, approximately**
- Robust IP66/67 (NEMA 4) GRN housing capable of being field or panel mounted
- Robust IP65 (NEMA 4) Aluminum housing capable of being field or panel mounted
- Scaled pulse output***
- Universal inputs
- Reverse polarity protection
- Flowmeter and pipe mount kits available
- PIN protected programming with simple programming flow-chart

**External power required for back light or pulse output features.

***Max. Output Frequency 20 Hz, K-factor must be divisible by 10.

SPECIFICATIONS

Display	Large backlit LCD 6-digit display with 8-digit secondary display line
Temperature Range	-4°F - +176°F (-20°C - +80°C)
Signal Input	Reed switch, Hall effect, Namur proximity detectors, voltage, current and coil (15mV P-P min)
Max. Input Frequency	Max. input frequency 5 kHz under external power. Maximum input frequency when not externally powered is 150 Hz
Signal Output	NPN transistor, scalable
Max. Output Frequency	20 Hz
Battery Power	3.6 V (dc), approximate 3 year life span
External Power	Regulated 8-24 V (dc) x 50 mA minimum
Protection Class & Body	IP65 (NEMA 4) Aluminium housing IP66/67 (NEMA 4) GRN housing
Mounting	Field, meter or panel mount
Engineering Units	Selectable Ltr, gal, m ³ , kgs, lbs (total). /s, /min, /hr or /day (rate)
Cable Entries	3 x M16 x 1.5, Aluminum housing 3 x 6mm drilled, GRN housing

DIMENSIONS

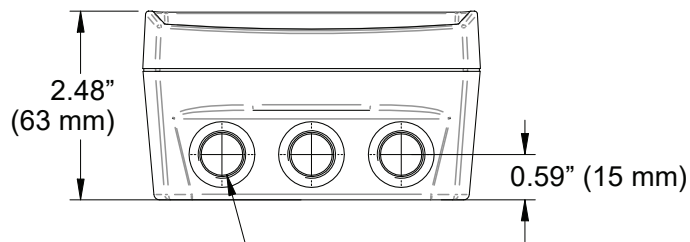
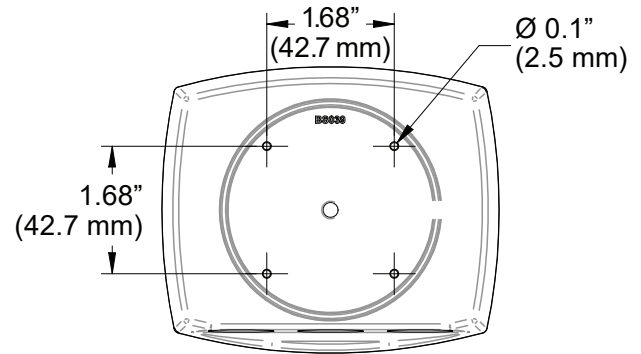
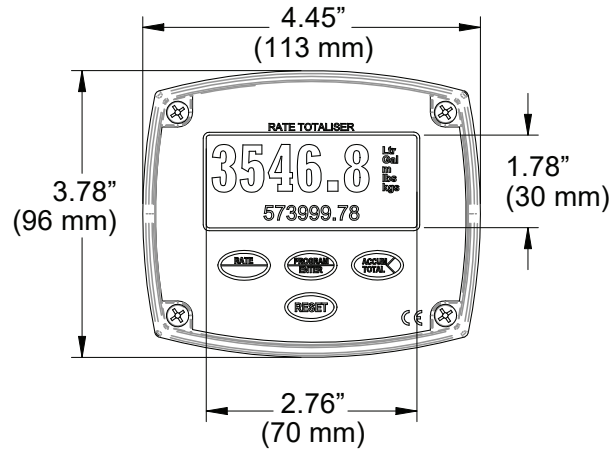

3 Conduit Entries
M16 x 1.5 (Aluminum)
or
16mm Drilled Holes (GRN)

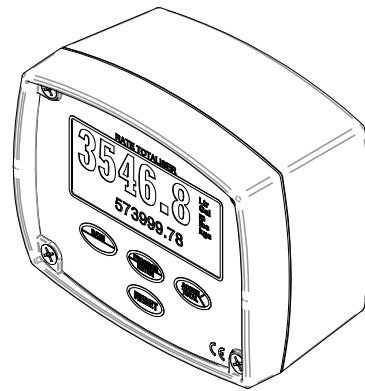

Service & Warranty: For technical assistance, warranty replacement or repair contact your **FLOMEC®** or **GPI®** distributor: In North or South America: **888-996-3837 / FLOMEC.net**
Outside North or South America: **+61 2 9540 4433 / FLOMEC.net**

Wichita · Sydney

GREAT PLAINS INDUSTRIES **GPI**